

Dimension:

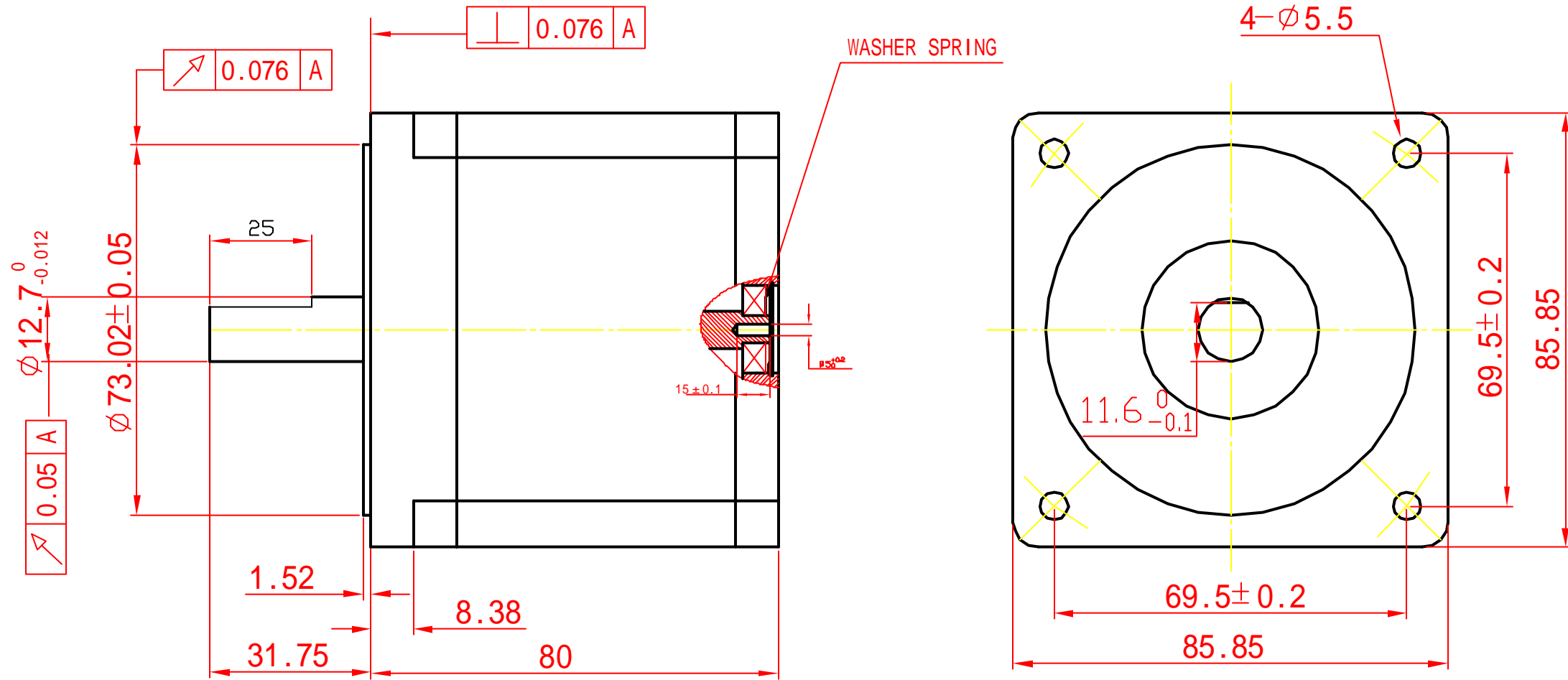

Specifications:

Wiring Diagram:

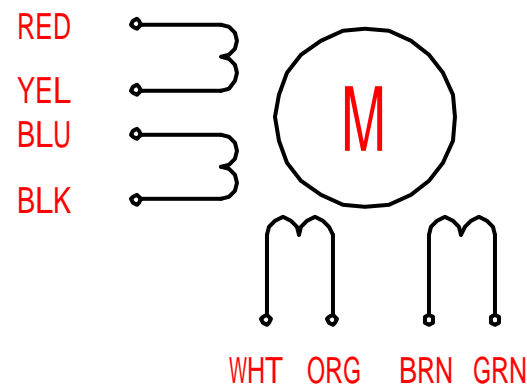

红黄蓝黑白橙棕绿
1007-AWG20# LENGTH 1000mm Min.

PHASE	STEP ANGLE	CONNECTION STYLE	CURRENT	RESISTANCE	INDUCTANCE	HOLDING TORQUE	ROTOR INERTIA	WEIGHT
	DEG/STEP		A	ohms	mH	N.m	gcm ²	Kg
4	1.8	parallel	6	0.4	3.5	4.5	1400	2.3
		series	3	1.6	14			
		unipolar	4.2	0.8	3.5	3.3		

DESIGN	DATE	P/N.
REVISION NO.	DESCRIPTION	TITLE
DRN	APP'D	DATE
UNLESS OTHERWISE SPECIFIED TOLERANCES:		SPECIFICATIONS
DECIMALS:	ANGULAR:	USED ON
.x ±0.5	±0°30'	FL86STH80-4208A-H
.xx ±0.25		DWG NO.
.xxx ±0.1		FX3.162.502SS
UNIT: mm	THIRD ANGLE PROJECTION	REV
DO NOT SCALE DRAWING	SCALE	FULLING MOTOR
	SHEET	OF