

Rulmenti lineari in carcasa seria SCxxWUU

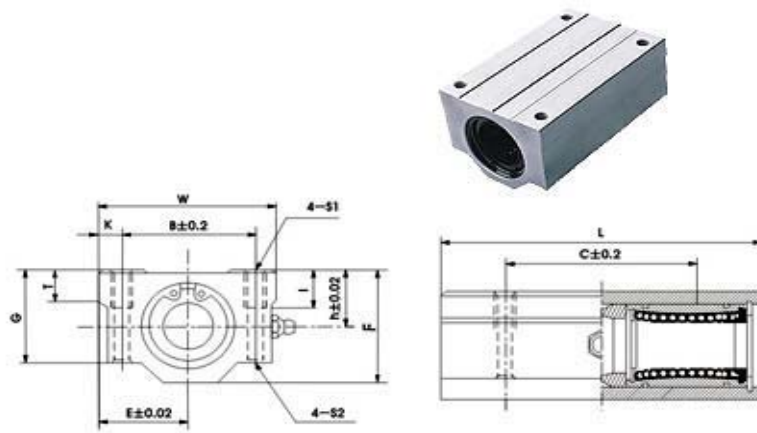

MODEL NO.	SHAFT		MAIN DIMENSIONS							MOUNTING DIMENSIONS					WEIGHT(kg)
	DIAMETER	h	E	W	L	F	G	T	B	C	K	S1	S2	I	
SC 10 WUU	10	13	20	40	68	26	21	8	28	46	6	M5	4.3	12	0.18
SC 12 WUU	12	15	21	42	70	28	24	8	30.5	50	5.75	M5	4.3	12	0.2
SC 16 WUU	16	19	25	50	85	38.5	32.5	9	36	60	7	M5	4.3	12	0.39
SC 20 WUU	20	21	27	54	96	41	35	11	40	70	7	M6	5.2	12	0.49
SC 25 WUU	25	26	38	76	130	51.5	42	12	54	100	11	M8	7	18	1.165
SC 30 WUU	30	30	39	78	140	59.5	49	15	58	110	10	M8	7	18	1.43
SC 40 WUU	40	40	51	102	175	78	62	20	80	140	11	M10	8.7	25	3.09
SC 50 WUU	50	52	61	122	215	102	80	25	100	160	11	M10	8.7	25	6.53

www.hi-end.ro